

OVS-TL

OSCILLATION VERTICAL SPINDLE SANDER

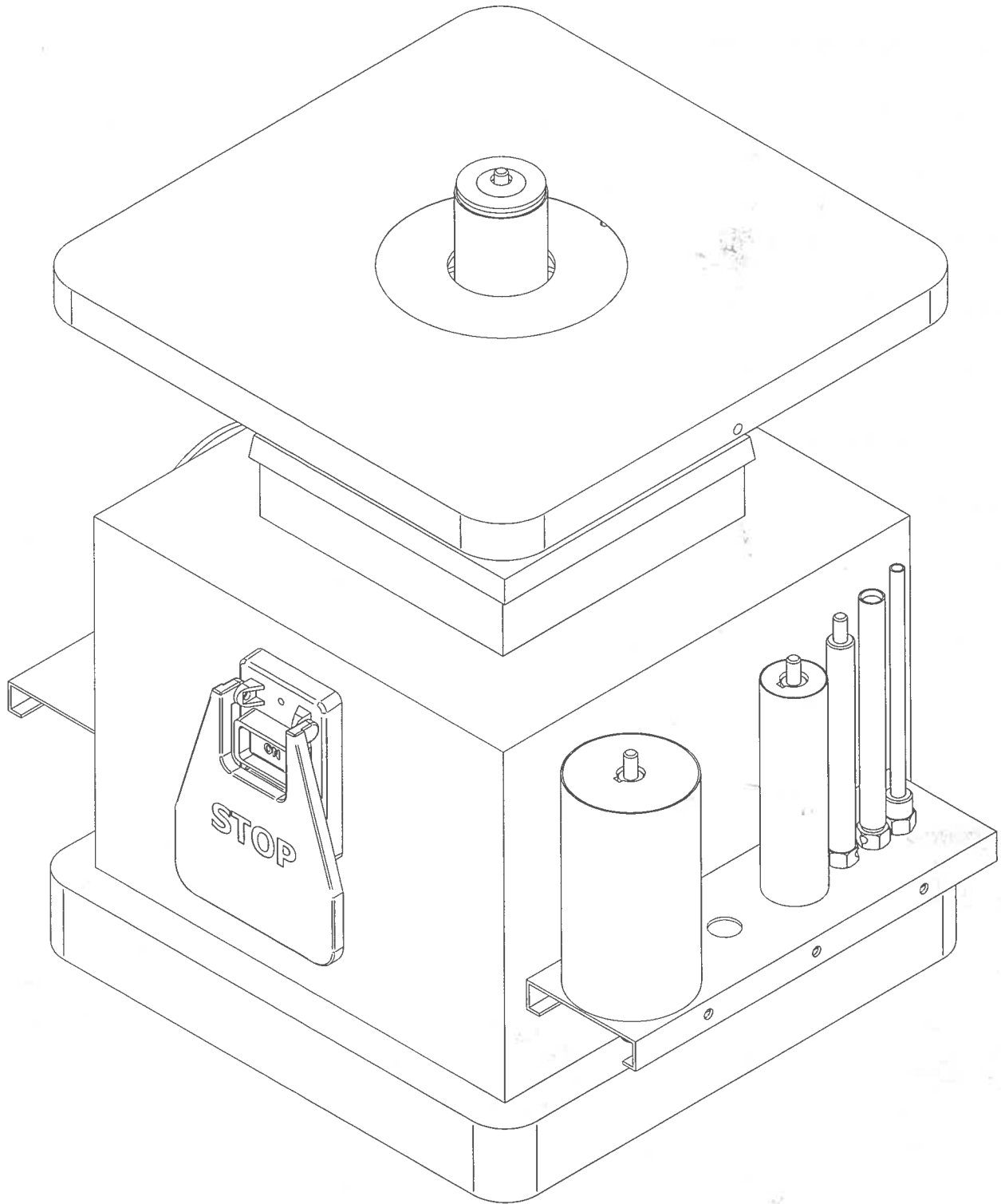

TABLE OF CONTENTS

Table of contents	1
Additional markings and safety instructions	2
Safety rules	2
Grounding instructions	3
Specifications	5
Machine legend	6
Machine dimension	6
Safe operating position	7
Power switch on / off	7
On/Off switch padlock	8
Instructions for operations	8
Tilting the table	9
Adjust the verticality between the table and drum	9
Mounting spindle drum	10
Selection guide for drum to table insert	11
Maintenance of spindle sander	11
Troubleshooting	12
Assembly drawing	13

ADDITIONAL MARKINGS AND SAFETY INSTRUCTIONS

1. The following warning or equivalent wording also appears on the Instruction Manual as well as on the tool per UL987. French equivalent of warning markings also appear on tool for Canada.
"WARNING: For Your Own Safety Read Instruction Manual before Operating Sander"
 1. Wear eye protection.
 2. Support work piece with work table.
 3. Maintain 1.6 mm clearance between table and sanding belt. The word "WARNING" shall be not less than 2.4 mm high.
2. An Instruction Manual warning user against of injury and precautions, grounding instructions, use of extension cords and important safeguards etc., per UL987 is provided with each tool.
3. The instruction manual for a scroll saw shall include the marking information as above and explanation of the use and construction of fixtures, including why and when they are needed.

SAFETY RULES

The safety instructions shall be as illustrated below or employ equivalent wording.

1. **KEEP GUARDS IN PLACE** and in working order.
2. **REMOVE ADJUSTING KEYS AND WRENCHES.** Form habit of checking to see that keys and adjusting wrenches are removed from tool before turning it on.
3. **KEEP WORK AREA CLEAN.** Cluttered areas and benches invite accidents.
4. **DON'T USE IN DANGEROUS ENVIRONMENT.** Don't use power tools in damp or wet locations, or expose them to rain. Keep work area well lighted.
5. **KEEP CHILDREN AWAY.** All visitors should be kept safe distance from work area.
6. **MAKE WORKSHOP KID PROOF** with padlocks, master switches, or by removing starter keys.
7. **DON'T FORCE TOOL.** It will do the job better and safer at the rate for which it was designed.
8. **USE RIGHT TOOL.** Don't force tool or attachment to do a job for which it was not designed.
9. **USE PROPER EXTENSION CORD.** Make sure your extension cord is in good condition. When using an extension cord, be sure to use one heavy enough to carry the current your product will draw. An undersized cord will cause a drop in line voltage resulting in loss of power and overheating. Table A shows the correct size to use depending on cord length and nameplate ampere rating. If in doubt, use the next heavier gage. The smaller the gage number, the heavier the cord.
10. **WEAR PROPER APPAREL** Do not wear loose clothing, gloves, neckties, rings, bracelets, or other jewelry which may get caught in moving parts. Nonslip footwear is recommended. Wear protective hair covering to contain long hair.
11. **ALWAYS USE SAFETY GLASSES.** Also use face or dust mask if cutting operation is dusty. Everyday eyeglasses only have impact resistant lenses, they are not safety glasses.

12. **SECURE WORK.** Use clamps or a vise to hold work when practical. It's safer than using your hand and it frees both hands to operate tool.
13. **DON'T OVERREACH.** Keep proper footing and balance at all times.
14. **MAINTAIN TOOLS WITH CARE.** Keep tools sharp and clean for best and safest performance. Follow instructions for lubricating and changing accessories.
15. **DISCONNECT TOOLS** before servicing; when changing accessories, such as blades, bits, cutters, and the like.
16. **REDUCE THE RISK OF UNINTENTIONAL STATING.** Make sure switch is in off position before plugging in.
17. **USE RECOMMENDED ACCESSORIES.** Consult the owner's manual for recommended accessories. The use of improper accessories may cause risk of injury to persons.
18. **NEVER STAND ON TOOL** Serious injury could occur if the tool is tipped or if the cutting tool is unintentionally contacted.
19. **CHECK DAMAGED PARTS.** Before further use of the too., a guard or other part that is damaged should be carefully checked to determine that it will operate properly and perform its intended function - check for alignment of moving parts, binding of moving parts, breakage of parts, mounting, and any other conditions that may affect its operation. A guard or other part that is damaged should be properly repaired or replaced.
20. **DIRECTION OF FEED.** Feed work into a blade or cutter against the direction of rotation of the blade or cutter only.
21. **NEVER LEAVE TOOL RUNNING UNATTENDED. TURN POWER OFF.** Don't leave tool until it comes to a complete stop.

GROUNDING INSTRUCTIONS

1. All grounded, cord-connected tools:
 In the event of a malfunction or breakdown, grounding provides a path of least resistance for electric current to reduce the risk of electric shock. This tool is equipped with an electric cord having an equipment-grounding conductor and a grounding plug. The plug must be plugged into a matching outlet that is properly installed and grounded in accordance with all local codes and ordinances.
 Do not modify the plug provided - if it will not fit the outlet, have the proper outlet installed by a qualified electrician.

Improper connection of the equipment-grounding conductor can result in a risk of electric shock. The conductor with insulation having an outer surface that is green with or without yellow stripes is the equipment-grounding conductor. If repair or replacement of the electric cord or plug is necessary, do not connect the equipment-grounding conductor to a live terminal.

Check with a qualified electrician or service personnel if the grounding instructions are not completely understood, or if in doubt as to whether the tool is properly grounded.

Use only 3-wire extension cords that have 3-prong grounding plugs and 3 pole receptacles that accept the tool's plug.

Repair or replace damaged or worn cord immediately.

2. Grounded, cord-connected tools intended for use on a supply circuit having a nominal rating less than 150 volts:

This tool is intended for use on a circuit that has an outlet that looks like the one illustrated in Sketch A in Fig. 1. The tool has a grounding plug that looks like the plug illustrated in Sketch A in Fig. 1. A temporary adapter, which looks like the adapter illustrated in Sketch B and C,

may be used to connect this plug to a 2 pole receptacle as shown in Sketch B if a properly grounded outlet is not available. The temporary adapter should be used only until a properly grounded outlet can be installed by a qualified electrician. This adapter is not permitted in Canada. The green-colored rigid ear, lug, and the like, extending from the adapter must be connected to a permanent ground such as a properly grounded outlet box.

Grounding methods

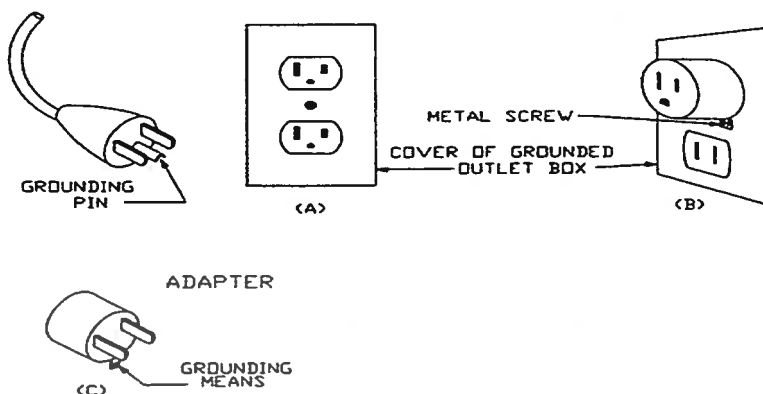
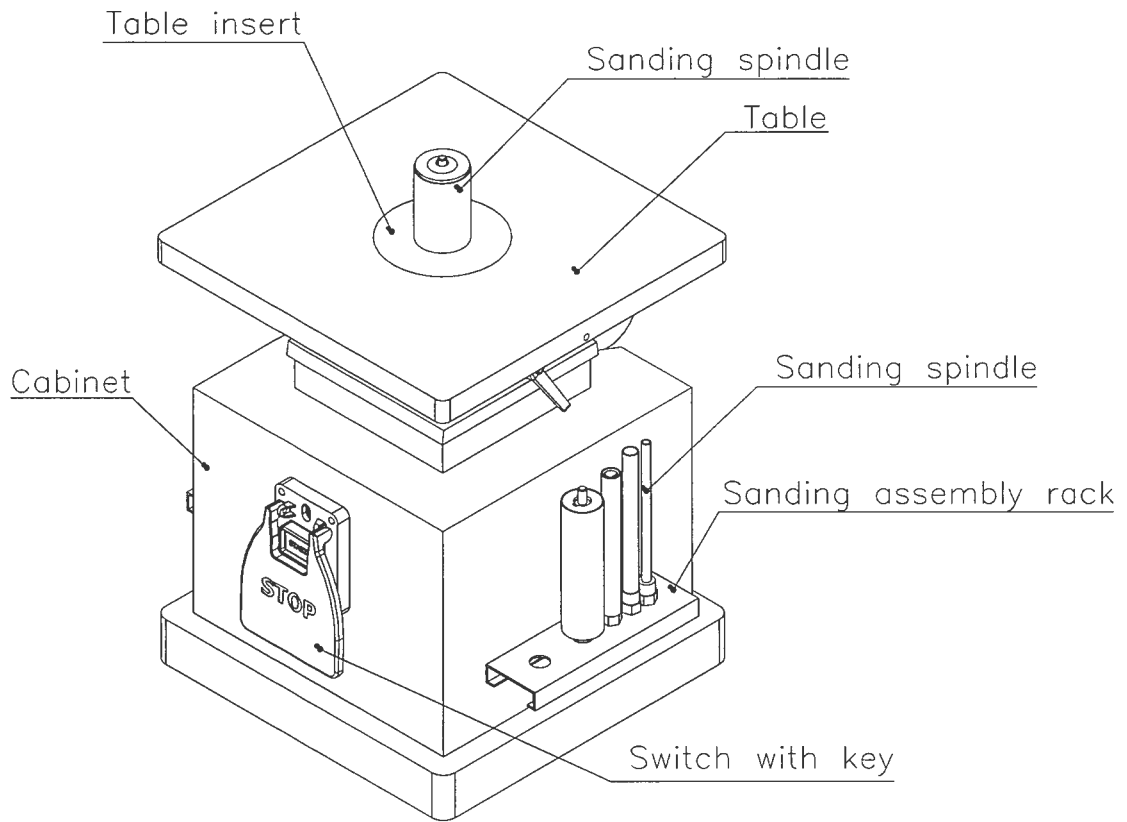

Table A						
Ampere Rating		Volts	Total length of cord in feet			
		120	25	50	100	150
		240	50	100	200	300
More Than	Not More Than		Minimum gage for cord			
0	6		18	16	16	14
6	10		18	16	14	12
10	12		16	16	14	12
12	16		14	12	Not Recommended	

SPECIFICATIONS

MODEL	OVS-TL
Table size (L x W)	370x370mm
Table tilt	0~45°
Spindle speed	1720rpm
Oscillations per minute	29
Oscillation stroke	24mm
Sanding sleeve length	141mm
Max. workpiece height	80mm
Dust port diameter	50.8mm
Motor	1/2HP /110V
Overall (L x W x H)	490x370x480mm
Net weight	35kgs

MACHINE LEGEND



MACHINE DIMENSION

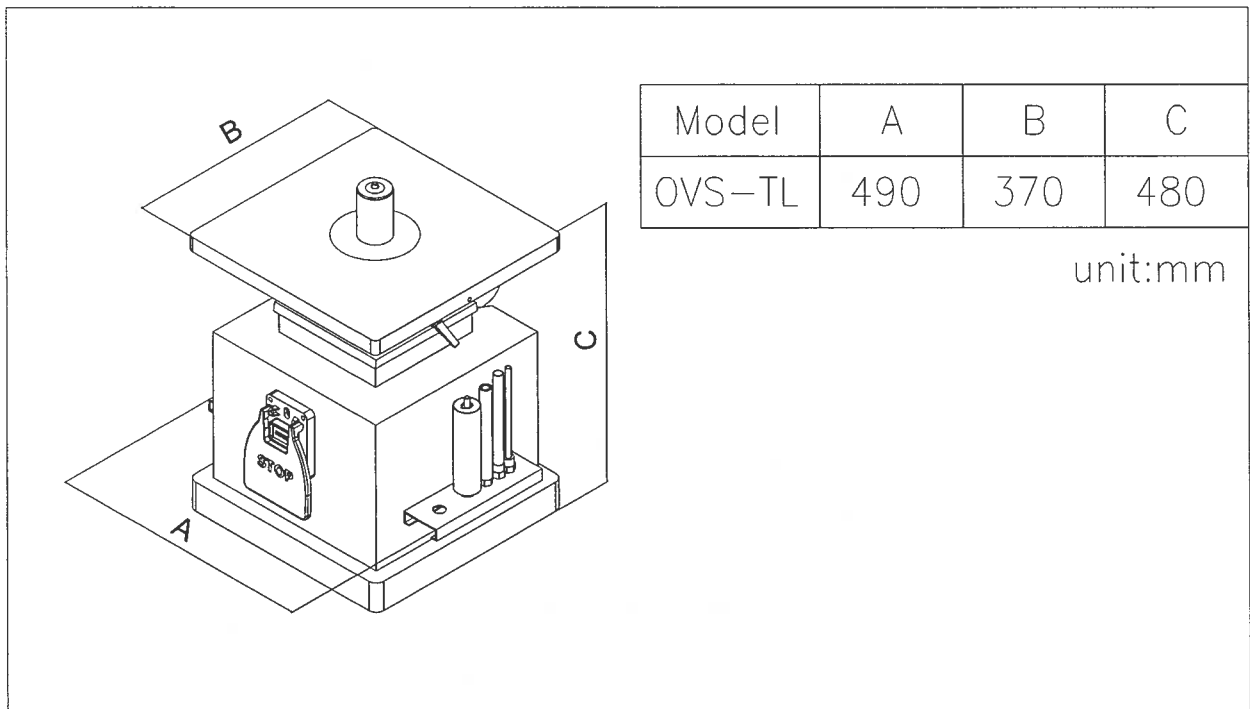

SAFE OPERATING POSITION

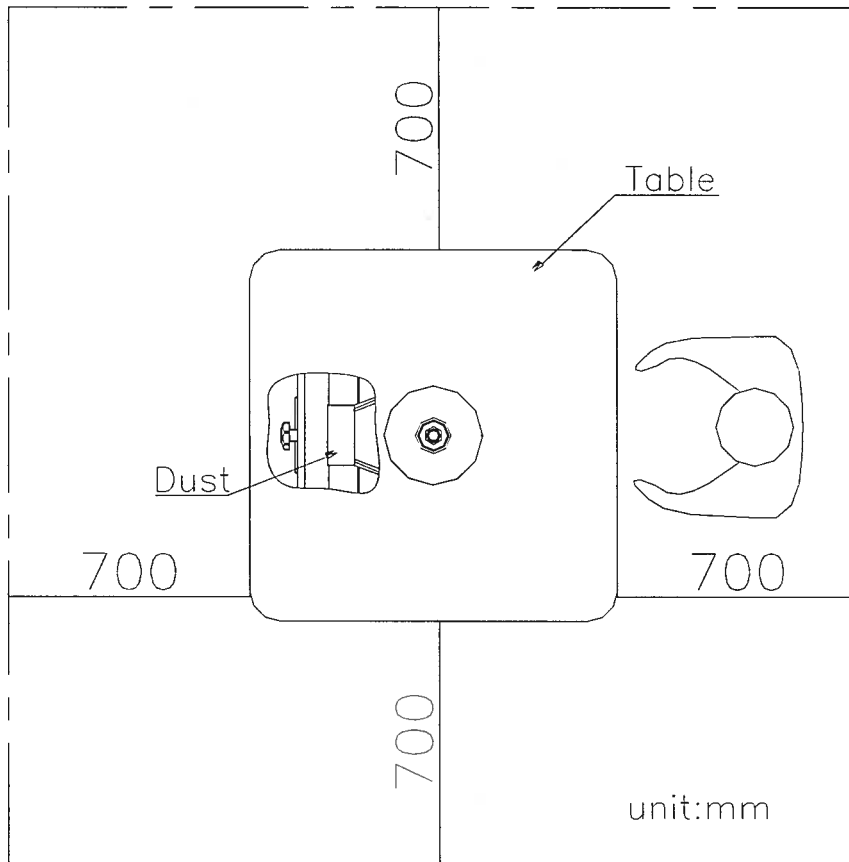

POWER SWITCH ON / OFF

Sanding machine assembly - magnetic switch which to start and stop the machine. The switch locations on the cabinet. When starts the machine the cover needs to be opened and press the button "ON". If you want to stop the machine, please press the button "OFF".

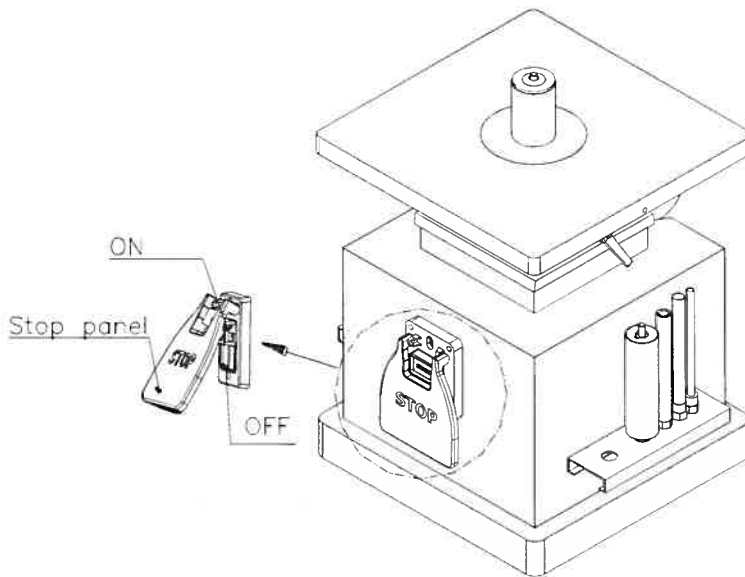

ON/OFF SWITCH PADLOCK

To avoid accidental starting by young children or others not qualified to use the tool, the use of a padlock is required.

To lock out an on/off switch:

1. open the padlock. See fig.A
2. insert through hole in the star button. See fig.B
3. close the padlock.
4. Place the key in a safe place out of the reach of children.

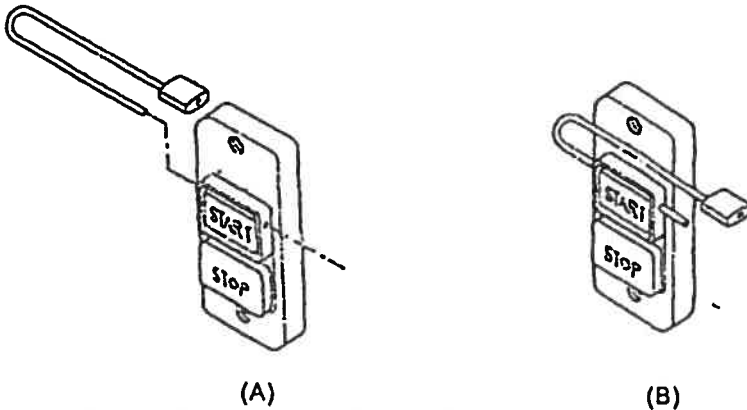

(A)

(B)

INSTRUCTIONS FOR OPERATIONS

1. Select spindle that is smaller than the curve to be sanded.
2. Use an insert plate that comes closest to the spindle without touching it.
3. Make sure that spindle is properly positioned in taper sleeve socket. With the wrench provided , tighten the nut. NOTE: Never over tighten; it may be difficult to remove the spindle later.
4. When table is set at a 90° angle, sanding may be done from any corner, or location on table around spindle.
5. When table is positioned at any angle other than 90°, it is necessary to position the work piece over the centerline, as shown on table surface.
6. Always lock the table with the hand nut when setting at any angle, also to prevent movement lock the tilting gear shaft.
7. Always loosen both table lock and tilting gear lock before changing the angle position of the table. Never force the table if it does not tilt easily, reason may be that the locks are still engaged. Never attempt to over ride the stop locks, this will cause damage to the tilting performance.
8. A backing board is recommended when sanding thin pieces of metal or any other material. A backing board can be easily constructed by using a piece of wood the length of the table, pushing it into the spindle until a half circle is formed. Clamp each end of the board to the table and proceed to sand the thin material.
9. Before leaving the machine remove any particles or pieces left over, make sure the table in 90°.

TILTING THE TABLE

1. Loosen the two table lock knobs (A), located under the table at both sides of the machine
2. Tilt the table forward to the desired angle with your hands.
3. An angle scale is provided at the right side of the trunnion to indicate the degree of table tilt.
4. Tighten the two table lock knobs securely after the table degree has been adjusted.

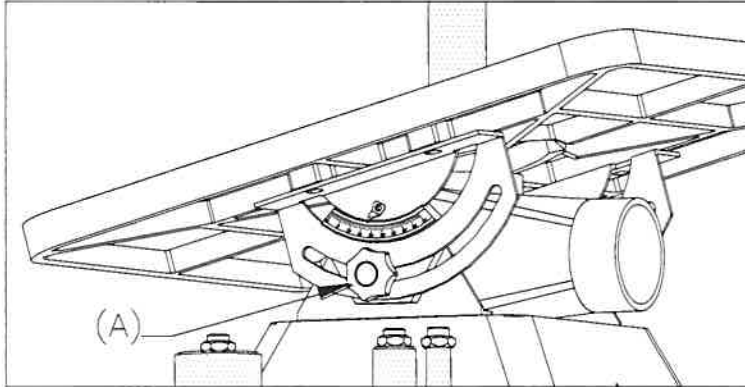

ADJUST THE VERTICALITY BETWEEN THE TABLE AND DRUM

1. The verticality between the table and drum has been adjusted by factory before shipment. However, after a long period of operation, the verticality may become inaccurate.
2. To adjust the verticality, set the table to a flat horizontal position. The table tilting scale should read zero degrees.
3. Place a 90° combinative square on the table and against the drum.
4. If the table is not 90° from the drum, adjust the angle of the table by changing the height of the resting post as shown.
5. If the table is 90° from the drum, but the scale does not read zero degree, set the scale to read zero degree by loosening the screw on the angle indicator and setting the arrow to zero.

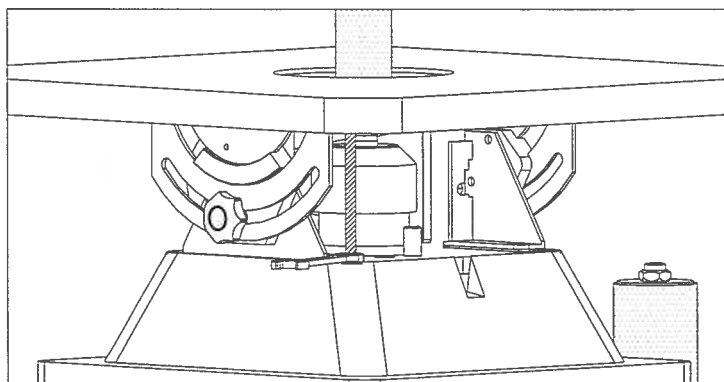

MOUNTING SPINDLE DRUM

1. Disconnect the sander from the power source.
2. Select the proper diameter of spindle drum.
3. Clean the taper part of the spindle drum before mounting it into the spindle.
4. Use an open-end wrench to lock the spindle by holding its flat surface. At the same time, use another open-end wrench to tighten the spindle drum.
5. Do not over tighten the spindle drum or it will be causing removable problem.



WARNING!

Disconnect the power source before removing the drum.

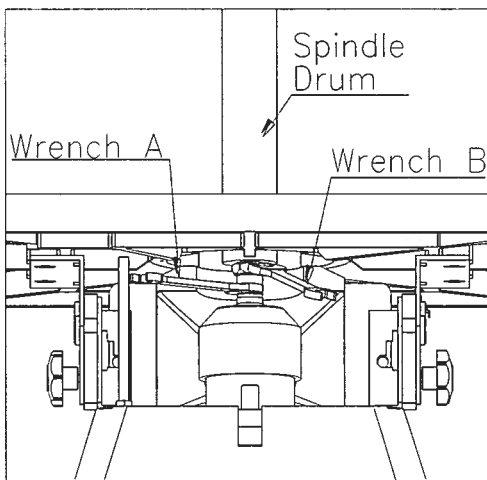

Use a wrench to lock the spindle. Use another wrench to loose the spindle drum.

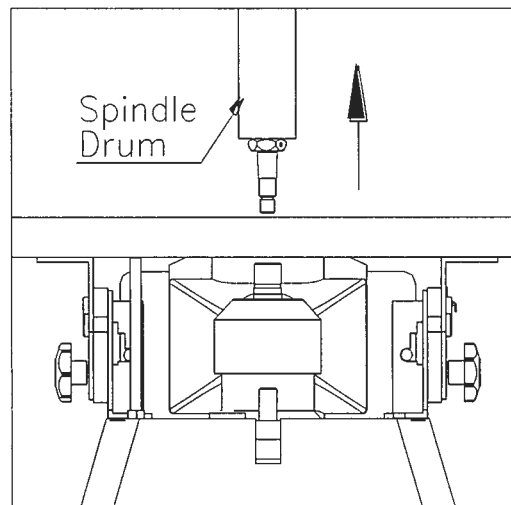

Removing an old spindle drum.

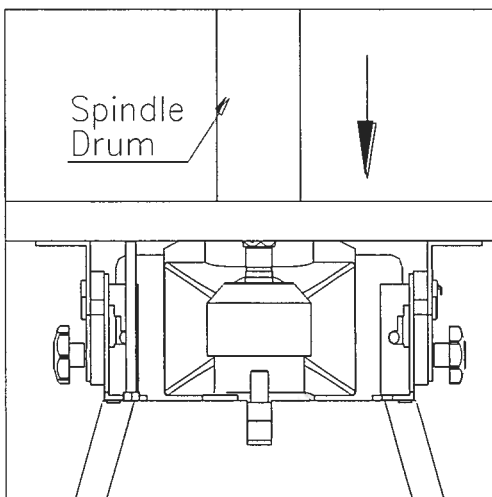

Fitting a new spindle drum.

SELECTION GUIDE FOR DRUM TO TABLE INSERT

This machine is furnished with 5 drums. The range of drum diameter is from 1/4" to 2". If the drum diameter is changed, the table insert needs to be changed to the proper size.

The table below shows which table insert to use for various drum diameters.



WARNING!

Failure to use the correct insert with the corresponding drum may result in injury!

Drum diameter	Table insert
# 1 1/4" Dia. x 6" long	# 1, # 2
# 2 1/2" Dia. x 6" long	# 1, # 2
# 3 5/8" Dia. x 6" long	# 1, # 2
# 4 1 1/2" Dia. x 5.6" long	# 3, # 4
# 5 2" Dia. x 5.6" long	# 3, # 4
# 6 3" Dia. x 5.6" long(Optional)	# 5

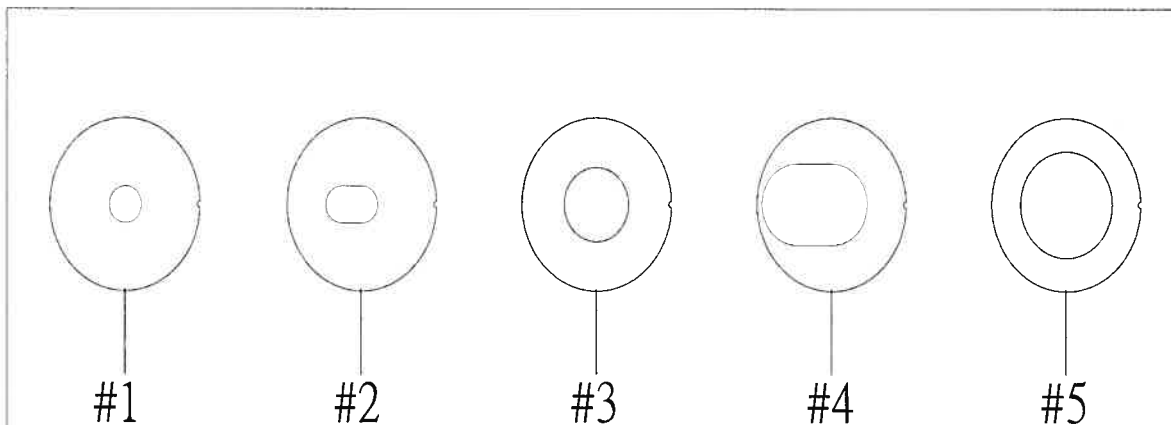

MAINTENANCE OF SPINDLE SANDER

1. To keep spindle sander in perfect condition, clean machine and attachments at all times.
2. Clean tapered sleeves and tapered socket before use, this will protect spindle sleeves from nicks.
3. Bent sleeves are easily straightened by placing them in the tapered socket and slipping a small pipe over the steel shaft. Using a dial indicator check that it is in correct position.
4. Check gearbox for proper oil level (Approx. 1/4 up on sight glass).
5. We recommend that a small amount of grease be applied to table tilting screw once a month.
6. No lubrication is required for the bearings, they are permanently lubricated.

TROUBLESHOOTING

TROUBLE	CAUSES	CORRECTION
Motor does not run when power switch is turned "ON".	<ol style="list-style-type: none"> 1. Switch is burned out. 2. Connection wire is loose or damaged. 	<ol style="list-style-type: none"> 1. Replace the switch. 2. Tighten or replace the wire.
Motor does not run at full speed.	<ol style="list-style-type: none"> 1. Power voltage is too low. 2. Motor is damaged. 	<ol style="list-style-type: none"> 1. Test voltage. 2. Check and repair motor.
Motor does not reach full power.	<ol style="list-style-type: none"> 1. Incorrect power wiring. 2. Overload. 	<ol style="list-style-type: none"> 1. Replace with the correct size power wiring. 2. Reduce sanding load.
Motor overheating	<ol style="list-style-type: none"> 1. Motor is dirty. 2. Motor is damaged. 	<ol style="list-style-type: none"> 1. Clean motor. 2. Check and repair motor.
Excessive machine vibration	Machine is incorrectly leveled.	Adjust machine leveling
Mark on workpiece	<ol style="list-style-type: none"> 1. Sanding drum is damaged. 2. Sanding cloth on drum is worn in some areas. 	<ol style="list-style-type: none"> 1. Replace the sanding drum. 2. Replace sanding cloth
Sanding drum turns in wrong direction	Wrong phase or voltage	Make sure the phase and voltage comply with machine requirement.
Burns on workpiece	Wrong abrasive grit on sanding cloth	Use coarser grit to remove more material from workpiece.

ASSEMBLY DRAWING

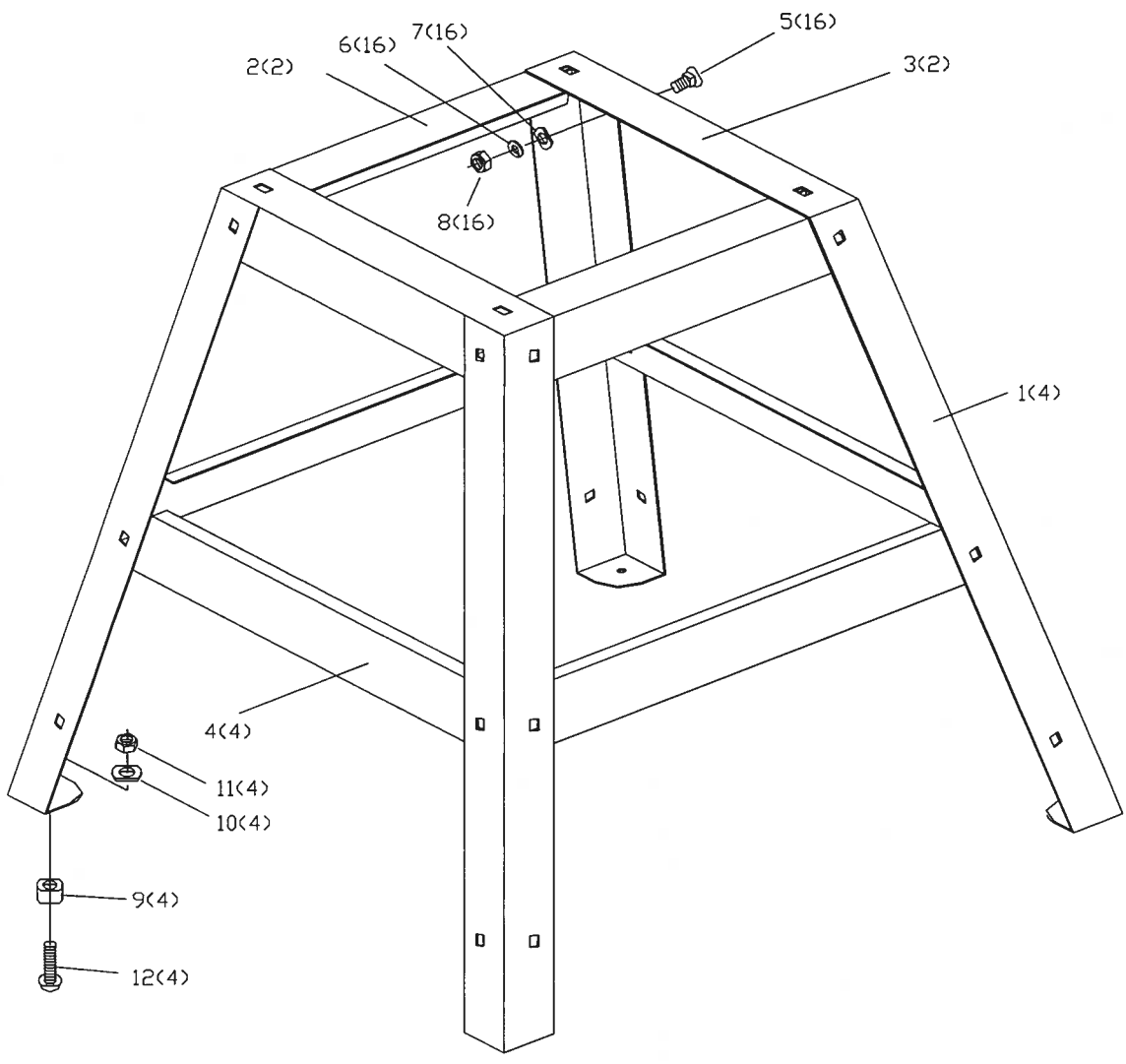

SPARE PARTS FOR OVS-TL

Key no.	Part no.	DISCRIPTION	Quantity
101	30201001L	BASE	1
101a	30201001a	TOP PLATE	1
103	S1006P1	STRAIN RELIEF	1
104	L000133a	POWER CORD	1
105	S0030622M	PHILIPS HEAD SCREW	4
106	10107098	RUBBER FEET	4
107	S0210403	FLAT WASHER	6
108	S0011600M	HEX. NUT	4
109	S0230300	SPRING WASHER	2
110	S0030318	PHILIPS HEAD SCREW	2
201	M329G211	MOTOR	1
202	S0430650	KEY	1
203	S0040415M	FLAT HEAD SCREW	1
204	30202001	WORM SHAFT	1
205	S0050610M	SET SCREW	2
206	30202002	TRANSMISSION ROD	1
207	S0110800M	HEX. NUT	1
208	30202003	CONNECTING ROD	2
209	S0210300	WASHER	4
210	S0120500M	LOCKING NUT	2
211	C1106804KY	BEARING	1
212	30202004	TRANSMISSION	1
213	C1106006	BEARING	1
214	S0520059	C RING	1
215	30202005	BUSHING	4
216	S0050506M	SET SCREW	2
217	S05ETW04	E RING	2
218	30202020	CONNECTING SHAFT	1
219	30202006p	BRACKET	1
220	30202007p	WORM	1
221	S0010615M	HEX. SOCKET CAP SCREW	4
222	30202008P	SHAFT	1
223	30204010	CRANK SHAFT	2
224	S0230400	SPRING WASHER	4
225	S0400415	KEY	1
226	C1106001	BEARING	2
227	S0521200	C RING	2
228	S0530028	C RING	2
229	S0230506	SPRING WASHER	11
230	S0210500C	FLAT WASHER	11
231	30202009	OIL CAP	1

SPARE PARTS FOR OVS-TL

Key no.	Part no.	DISCRIPTION	Quantity
232	30202012	STORAGE PLATE FOR SPINDLES	1
233	30202013	STORAGE PLATE FOR INSERTS	1
234	30202014	OIL PLUG	1
235	S0030304	ROUND HEAD SCREW 3/16"-24UNC*1/4"	2
301	30203001	HOUSING	1
304a	30203003	BRACKET (RIGHT)	1
304b	30203003a	BRACKET (LEFT)	1
305	S0020825M	HEX. SCREW	11
306	S0020811M	HEX. SCREW	1
308	S0110600	HEX. NUT	1
310a	40501011	SUPPORT TRUNNION (RIGHT)	1
310b	40501011a	SUPPORT TRUNNION (LEFT)	1
311	30204013G	LOCK KNOB	2
312	S0010516M	HEX. SOCKET CAP SCREW	4
313	S0050606M	SET SCREW	1
314	10102022	POINTER	1
315	S0220400	GEAR WASHER	1
316	S0030510M	PHILIPS HEAD SCREW	1
317	30203005	DUST COVER	1
319	30203006	MAIN SPINDLE	1
320	30203007	SWITCH COVER	1
322	S0520028	C RING	1
323	30203000H	3" SPINDLE ASS'Y	1
323a	30203020	3" SANDING SLEEVE 100 GRIT	1
324	30203000E	2" SPINDLE ASS'Y	1
324a	30203021	2" SANDING SLEEVE 100 GRIT	1
325	30203000D	1-1/2" SPINDLE ASS'Y	1
325a	30203013	1-1/2" SANDING SLEEVE 100 GRIT	1
326	30203000I	5/8" SPINDLE ASS'Y	1
326a	30105076	5/8" SANDING SLEEVE 100 GRIT	1
327	30203000B	1/2" SPINDLE ASS'Y	1
327a	30105079	1/2" SANDING SLEEVE 100 GRIT	1
328	30203000A	1/4" SPINDLE ASS'Y	1
328a	30203022	1/4" SANDING SLEEVE 100 GRIT	1
401	30204001	TABLE	1
407	30204003Q	2" TABLE INSERT (OVAL)	1
408	30204004	2" TABLE INSERT (ROUND)	1
409	30204005	3/4" TABLE INSERT (ROUND)	1
410	30204006Q	3/4" TABLE INSERT (OVAL)	1
411	30204007	3" TABLE INSERT (ROUND)	1

SPARE PARTS FOR OVS-TL

Key no.	Part no.	DISCRIPTION	Quantity
412	S0310312	SPRING PIN	1
413	30201003	WRENCH	1
414	10105091	WRENCH	1
416	J8010004	WARNING LABEL	1
419	WG000007	SWITCH COVER	1
419a	WG000002	SWITCH BOX	1
419b	WG000003	SWITCH PIN	1
425	30202039	RUBBER PAD	4
426	S0520019	RING STW-19	1
427	S0110500L	HEX. NUT 5/16"*18UNC*LH	1

STAND

1	30201001B	STAND	4
2	30205001G	TOP PLATE (A)	2
3	30205002G	TOP PLATE (B)	2
4	30201001D	TIE BAR	4
5	S0060509	CARRIAGE BOLT	16
6	S0230506	SPRING WASHER 5/16"	16
7	S0210500C	WASHER	16
8	S0110500	NUT 5/16"	16
9	10107098	RUBBER FEET	4
10	S0210403a	WASHER 1/4"	4
11	S0110600M	NUT 1/4"	4
12	S0030625M	RD. CROSS SCREW M6xP1.0x25L	4